

Automated Instrument Washer-Disinfectors  
are the first step in the sterilization process



G4 Technology  
Information  
at your fingertips



*SciCan*

**HYDRIM<sup>®</sup>** C61wd G4

### **Product Advice Sheet**

Recommended protocol for decommissioning  
unit during prolonged periods of inactivity.

 **COLTENE**

If your Hydrim unit has been idle for a prolonged period of inactivity, (e.g. for > 2 weeks) Scican recommend that a series of checks and set-up procedures are undertaken before the unit is returned to clinical use so that its operation will not compromise the efficacy of your instruments when first used.

The following procedure is based on the assumption that during the period of inactivity, the unit and its accessories have been drained of all fluids and cleaned.

## 1. MAIN UNIT

- 1.1. Ensure main power cable is attached and plugged into the supply socket and power on the unit.
- 1.2. Ensure hot and cold feed pipes are connected and secure and turn on the water supply to each feed.
- 1.3. Ensure that the drain tube is connected, secure and is located in the waste system correctly.

## 2. SOLUTION CONNECTION

- 2.1. Open the main door to access the solution cassette.
- 2.2. Locate solution pouch. This can be either a part used or new pouch.
- 2.3. Place the solution pouch in the cassette, (note position of connector in cassette)
- 2.4. Push the cassette and pouch into the location slot in the unit. (Ensure that the tubing is not kinked.)
- 2.5. Pull out the feed tube and screw the feed tube connector to the connector on the solution pouch.

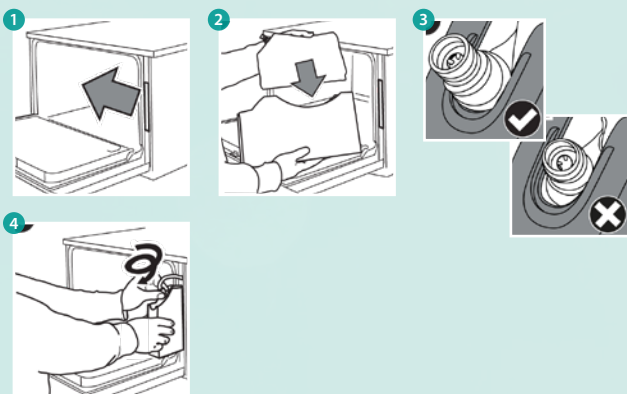

- 2.6. To prime the dosing system, look on the LCD screen of the unit and on the main menu select the detergent/salt icon. The next screen will show a **red cross** opposite the word 'Detergent'.
- 2.7. Click on this icon to prime the system between the connector and the dosing reservoir. The **red cross** should change to a **green check mark** (tick).

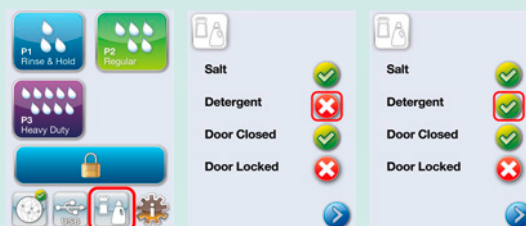

## 3. CHECK SALT LEVEL

- 3.1. To check the salt level, look on the LCD screen of the unit and on the main menu select the detergent/salt icon. The next screen MAY show a red cross opposite the word 'Salt'.
- 3.2. If the icon shows a green check mark (tick) then the salt level is OK and you can proceed to the next phase.
- 3.3. If not, unscrew the salt container lid.
- 3.4. Check that there is water in the container, if not top up to the top of the container rim.
- 3.5. Now fill the container up to the rim with salt tablets. Note: It is normal for water to spill out of the container, but this will be removed from the chamber when the unit first starts.
- 3.6. Replace the salt container lid. (The salt icon should now show a green check mark (tick).

## 4. PREPARING THE UNIT FOR FIRST CYCLE

### 4.1 CHECK THE CHAMBER FILTERS FOR DEBRIS AND BLOCKAGES.

- i. Lift out and inspect the coarse filter in the bottom of the chamber and clean by rinsing under running water.
- ii. Inspect the fine filter located below the coarse filter. Note: this should not be removed by the user.
- iii. To clean the fine filter, remove the coarse filter, and remove any debris with water and a stiff bristled non-metallic brush.

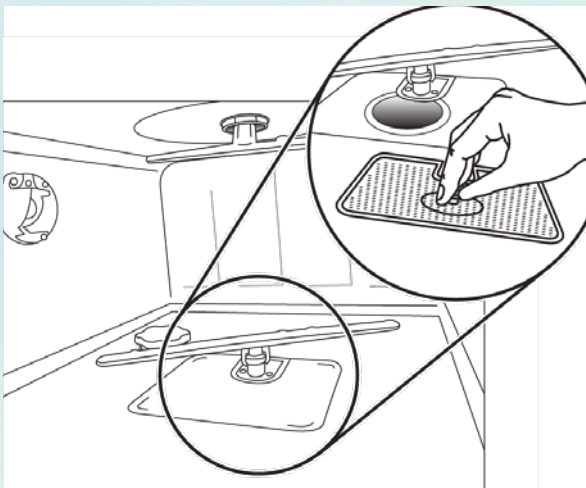

### 4.2 CHECK WASH ARM ROTATION.

- i. Open the main door and manually rotate the wash arms to ensure they are rotating freely.
- ii. Visually inspect the wash arm spray nozzles for debris.
- iii. If they are not turning easily or debris is spotted in the spray nozzles, remove the wash arms and clean under running water.
- iv. To remove the upper and lower wash arms, pull them up, or down as appropriate towards the centre of the chamber. Some resistance will need to be overcome to disengage the locking tabs.

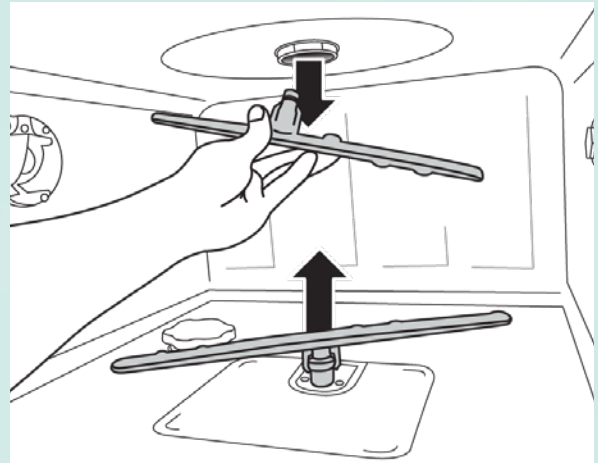

### 4.3 RUN A CLEANING CYCLE TO REMOVE ANY RESIDUAL DEPOSITS FROM THE CHAMBER.

- i. Ensure that the load carrier (trolley) is in place and close the main door.
- ii. Run the cleaning cycle including white vinegar as recommended. Note, Citric acid may be used as a substitute for white vinegar.
- iii. Pour 0.5 litres of white vinegar into the chamber before starting the cycle. To activate the cleaning cycle, close the main door and select the cycle from the user menu as follows.



- IV. When the cleaning cycle has been completed, the unit should now be ready to run a normal cycle.

## 5. RUN A TEST CYCLE

**⚠ A TEST CYCLE IS REQUIRED TO ENSURE THAT ALL THE COMPONENT PARTS FUNCTION CORRECTLY, THE CHAMBER IS DISINFECTED READY FOR USE AND THE DOSING SYSTEM IS FULLY PRIMED WITH SOLUTION.**

**5.1.** Close unit main door.

**5.2.** Go to main screen and select/start a P3 (Heavy Duty Wash and Thermal Disinfect) cycle.



Your Hydrim unit should now have been fully prepared for clinical use. The unit may now be loaded with your preferred instrument support baskets/racks, instruments loaded as required and be run as normal.

**Note:** It is important to follow the recommendation of your local guidelines for the appropriate process efficacy testing requirements after a period of non-use (e.g. Load protein testing).

In the unlikely event that the unit faults for any reason that you cannot resolve by resetting and running another cycle, or the efficacy testing fails, please make a note of the fault and contact your local dealer's service department for advice.